

Voltage-Inverter IC Forms High-Efficiency Rail Splitter

A switched-capacitor voltage inverter configured as a "rail splitter" (IC1 in **Figure 1**) provides a bipolar (dual-rail) local power supply that is useful in single-rail systems featuring one or more dual-rail ICs. Moreover, the tiny SOT-23 package and associated components require very little board area.

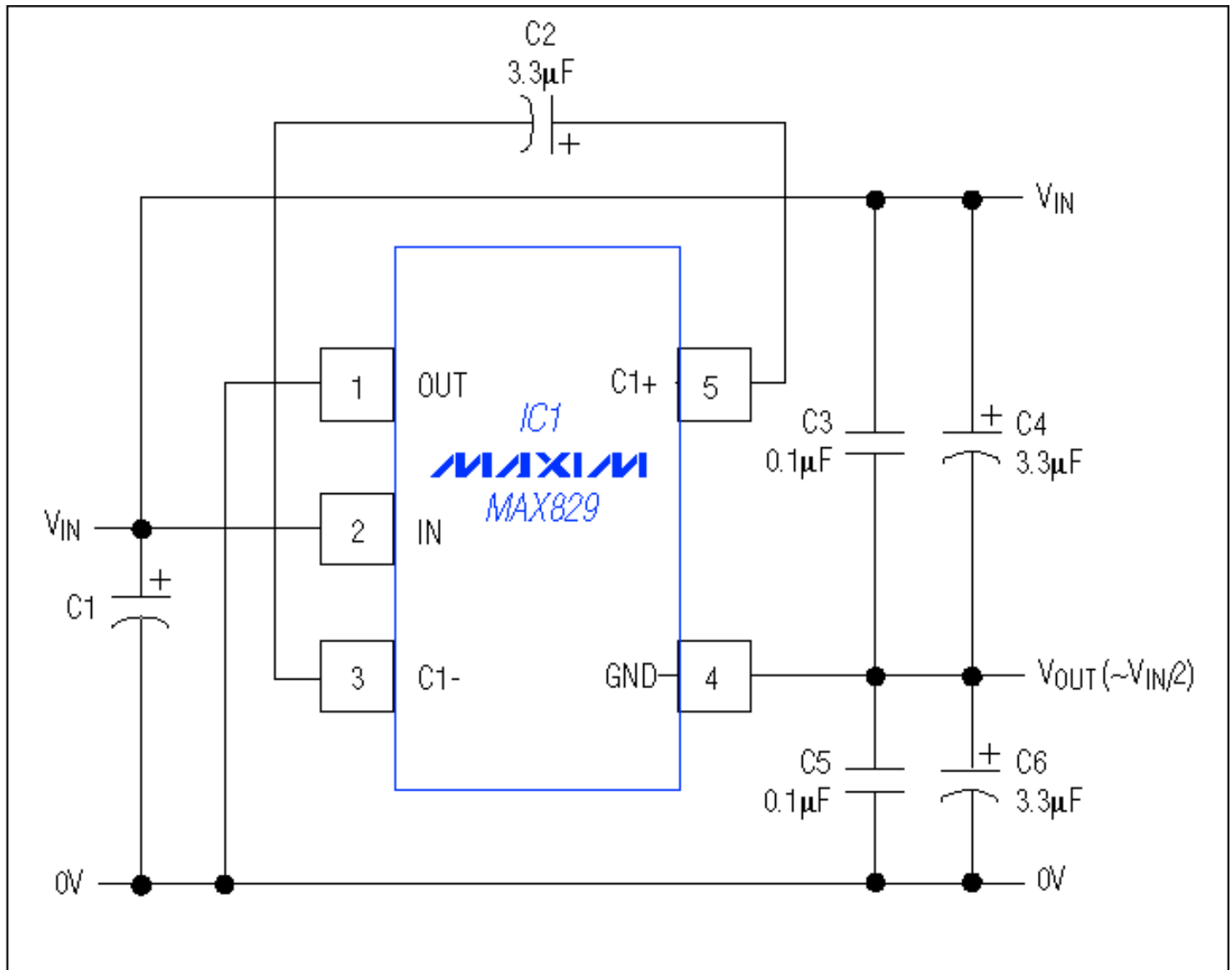

Figure 1. This compact and efficient charge-pump circuit implements a local dual-rail supply for single-rail systems.

After power is applied, the flying capacitor (C2) connects alternately across the storage capacitors C3/C4 and C5/C6. This action equalizes the voltages on those capacitors and draws current from VIN or VOUT as required to maintain $V_{OUT} = 1/2V_{IN}$.

If the loads across VIN-VOUT and VOUT-0V are equal, the IC sits in a quiescent state and draws about 36µA. To

keep VOUT at the mid-rail level, the flying capacitor needs only to supply the difference current caused by unbalanced loads. Efficiency is degraded by the IC's quiescent current for load currents below 100 μ A, but above 1mA the efficiency is greater than 90%-an excellent feature for low-power or battery-powered applications. (Voltage error and efficiency vary with the load current, as shown in **Figures 2** and **3**.)

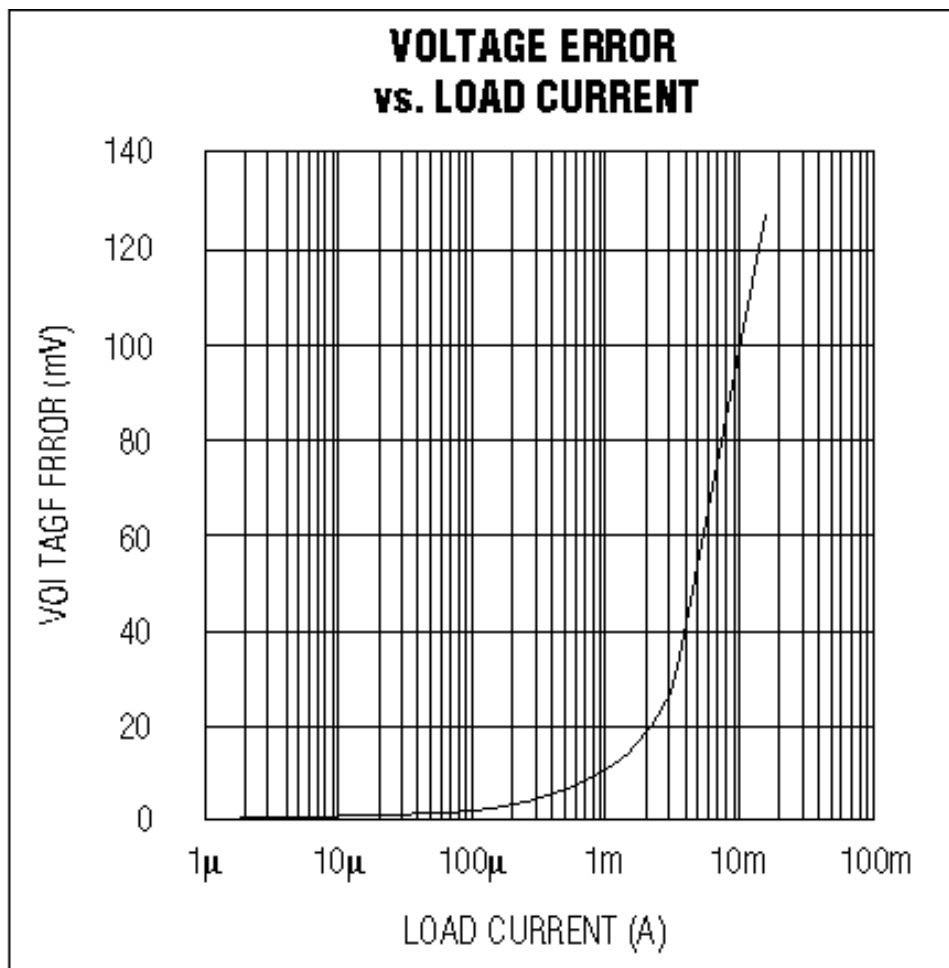

Figure 2. The output voltage error in Figure 1 increases with load current.

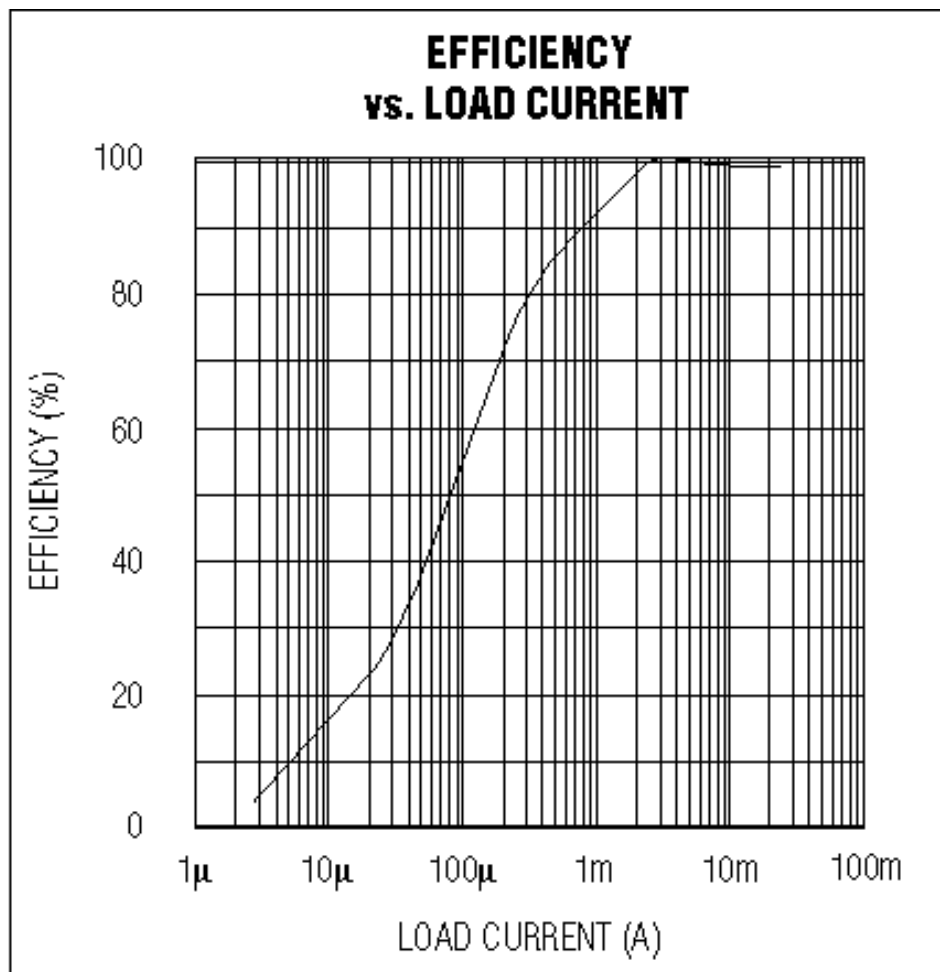

Figure 3. Efficiency also increases with load current in Figure 1.

This switched-capacitor circuit provides better regulation than that of a simple voltage divider, and better efficiency than that of a simple combination of divider and op-amp buffer. Its main drawback is the increase in output noise with load (see **Table 1**). V_{IN} is restricted (by the IC specifications) to a maximum of 5.5V, which is the maximum voltage allowed between pins 2 and 4 or between pins 1 and 4.

R_{LOAD} (Ω)	INPUT CURRENT (μA)	V_{OUT} ERROR (mV)	OUTPUT CURRENT (μA)	RIPPLE (mV _{p-p})	EFFICIENCY (%)
∞	36.5	—	—	—	—
10M	36.5	—	0.25	—	0.34
1M	37.7	—	2.5	—	3.32
100k	48.9	0.1	25	—	25.56
10k	156	1.4	250	~1	80.04
1k	1240	13.5	2490	~5	99.72
470	2630	28.5	5260	~8	98.83
100	11,410	126.9	23,700	~30	98.71

A similar idea appeared in the 8/1/97 issue of EDN.

More Information

MAX829: [QuickView](#) -- [Full \(PDF\) Data Sheet](#) -- [Free Samples](#)